

Research on Gear Tooth Longitudinal Modification of Locomotive Traction Gear with Shaft Structure

Xiaochun Shi^{1*}, Riming Zhang¹, Weidong He¹

RESEARCH ARTICLE

Received 18 June 2017; accepted 22 February 2018

Abstract

By the contact analysis of the traction gears with shafts of high-speed and heavy-load locomotive, the deformation and load distribution of the Front Guide Surface in starting operation are obtained. According to the results, the ideal longitudinal modification curve is fitted out. The gear parametric models were completed, and the load distribution and the contact stress of the gears are compared before and after tooth longitudinal modification in ANSYS. It shows the modification methods and the amount of the modification are reasonable.

Keywords

locomotive traction gear, finite element analysis, tooth longitudinal modification, crowned tooth

1 Introduction

Locomotive traction gears are the core part of the walking and power transmission devices in railway vehicles. Traction gears are composed of cylindrical gears. Torque generated by the traction motor is passed to the pinion through motor shaft, and drive the driven wheel.

In the process from starting, sustain, to the rapid operation, the traction gear works under different conditions, it has high linear velocity and large load variation. In addition, in the meshing process, a variety of gear errors and deformations will be produced by load, and the deformation of the component connected with the gear is quite obvious. The results are: the relative position of the gear pair is changed; partial load and impact phenomena are generated; abnormal wear of gear tooth will be caused seriously. Therefore, the focus of traction gearing design is: long service life, high reliability, low maintenance costs.

At present, locomotive transmission mainly has two types of structures which are axle box type transmission structure and the hollow axle type transmission structure. The axle box type transmission structure is taken as an example (as Fig. 1 and Fig. 2) in this paper. With the aid of design language (APDL) in ANSYS, several studies about traction gears are going to be performed as follows: the tooth surface contact stress and tooth root bending stress (Consists of two kinds of circumstances, only a pair of gears and a pair of gears considering shaft structures), the axial deformations of gears, tooth axial modification of the gears and so on.

2 Establish the finite element model

2.1 Establish the finite element model of standard involute gear and its supporting shafts

The geometric parameters of the traction gear are: modulus: 9.5 mm; tooth number: $z_1 = 16$, $z_2 = 91$; tooth width: 130 mm; center distance: 515 mm. The physical parameters are: Elastic modulus: 206 GPa; Poisson's ratio: 0.3; mass density: 7800 kg/m³.

First, according to the design radius of top circular arc of single round grinding hob, the standard involute equation and

¹ Department of Mechanical Drive, School of Mechanical Engineering, Dalian Jiaotong University, 347#, 116000, China

* Corresponding author, e-mail: shilinkang@sina.cn

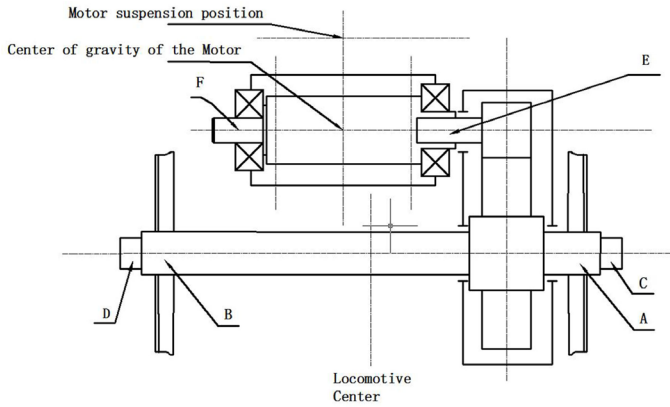

Fig. 1 Structural diagram of locomotive traction mechanism

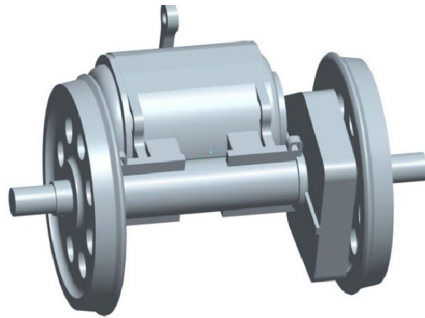

Fig. 2 The axle box type transmission structure

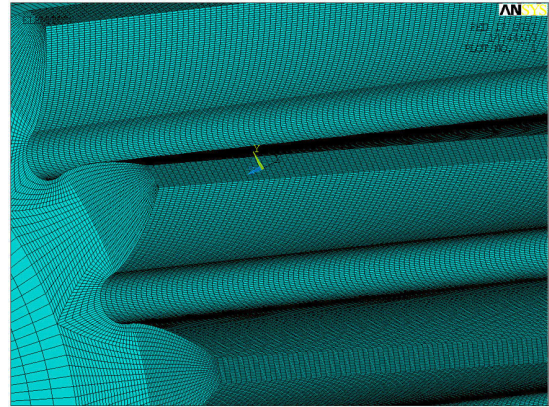

Fig. 3 Mesh division of small gear teeth

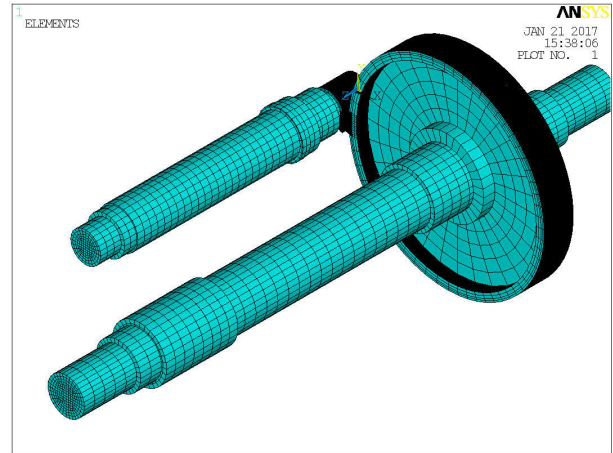

Fig. 4 Structure diagram of the traction gear and shafting

dedendum transition curve equation, the parameterized model of standard involute gear tooth profile is established.

According to the involute equation (1), α_k as the independent variable (its range changes from 0 to α_a , α_a is the addendum circle pressure angle), a series of keypoints can be gotten by setting the steps and linked them with smooth spline curve, the involute can be formed (Sun and Chen, 2003).

$$\begin{cases} x = \frac{r_b}{\cos \alpha_k} \cos (\varphi_B + \theta_K) \\ y = \frac{r_b}{\cos \alpha_k} \sin (\varphi_B + \theta_K) \end{cases} \quad (1)$$

Because of the length, the meaning and description of the symbols in the Eq. (1) are shown in Fig. 20 and Eq. (8).

Three teeth are selected to establish the model according to the contact ratio. The SOLID185 unit was used to establish 3 gears contact finite element model. Elements TARGE170 and CONTA173 are adopted to simulate the 3D target surface and contact surface. To ensure the accuracy of gear tooth surface contact analysis, the mapping grid is adopted to mesh the finite element model of gear pair, namely hexahedral solid elements. The mesh density of various profile curves can be assigned by statement LESIZE, so as to adjust automatically the mesh density of the tooth profile or spoke according to the need (He et al., 2011). The model of helical gear is shown as Fig. 3.

In the process of meshing gear pair, the bearing capacity of the gears is influenced deeply by the bending deformation and torsion deformation of the shaft. For a detailed analysis about

the load distribution along the gear's tooth width affected by the elastic deformation of the shafts, and also for the follow-up design and analysis of tooth modification, the models of shafts are set up with the gears at the same time and coupled together. In the process of meshing, only the grids of tooth surface contact portion and root bending portion need to be refined in order to ensure the accuracy of the calculation and save computing time. The complete model is shown as Fig. 4.

2.2 Boundary Conditions

2.2.1 Boundary Constraint Conditions of a pair of gears with shaft structures

According to the loads in driving process of the locomotive, the restrained position of the axle is set in the position of two wheels, as Fig. 1. All nodes in point A are installed full restraint, and the nodes in point B are only retained axial degree of freedom.

Since the role of driving torque, the pinion is rotated in the circumferential direction to the driven wheel contact surface, and its freedom of rotation in the circumferential direction can't be limited. So the nodes in the position E and F of the shaft corresponding to motor support bearing surface are selected. The radial and axial freedoms of the nodes in points E are restrained, while the radial freedoms of the nodes in F are

restrained, and its axial freedom are retained. The pinion can rotate freely about the axis and moved axially in point F.

2.2.2 Load Conditions

a. Only a pair of gears

Full constraints are imposed on all nodes of inner bore in big gear. The pinion receives the drive torque T in the circumferential direction, the radial and axial degrees of freedom of all nodes in inner bore are constrained, but its rotational degree of freedom is not retained. Due to the nodes of SOLID185 element have no rotational degree of freedom, the method of driving torque applied on the pinion is the node of the pinion shaft hole inner surface should be converted into cylindrical coordinates and tangential force F is applied to the nodes on the surface of motor shaft. Thus uniform torque T is indirectly exerted on the pinion (Shang and Wang, 2009), shown as Fig. 5.

$$F = T / (r \times N). \quad (2)$$

Where: F -average tangential force, r -radius of the armature shaft, N -total number of the nodes on the surface of the shaft hole (Wu et al., 2012).

b. A pair of gears with shaft structures

The gravity of parts is applied by way of gravitational acceleration and calculated automatically by the software, the gravitational acceleration is 9800 mm/s^2 . The weight of carriage supported by the axle is applied directly to the nodes of two cylindrical surfaces in position C, D; the loads acting on the axle journal are 98.15 KN . The driving torque is applied on the armature shaft, method as above.

In the cylindrical coordinate system, due to the driving torque, the driving pinion will rotate around the axis, so its rotational freedom in the circumferential direction can not be restricted. Constrain the UX , UZ directional degrees of freedom at position 1 of the motor shaft, while constrain the UX directional degree at position 2, and retain its axial and rotational freedoms, allow the pinion to rotate freely about its axis

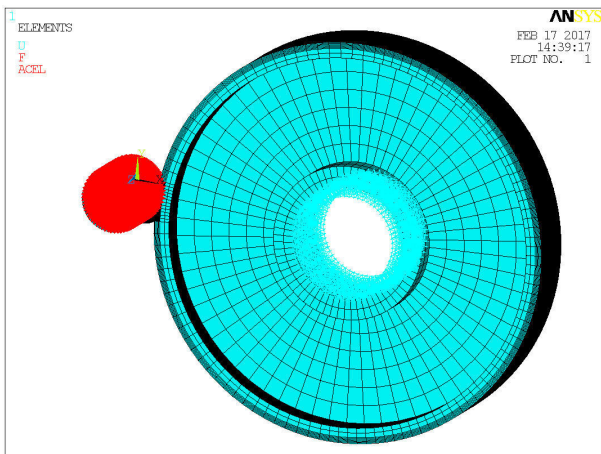

Fig. 5 Load diagram of only a pair of gears

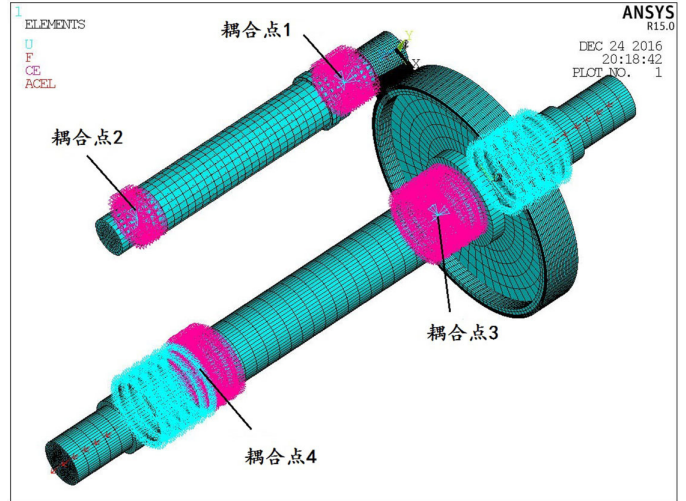

Fig. 6 Load diagram of the gears with shafts

and move axially. In the big axle, at the position 3, constrain UX , UY , UZ directional degree of freedoms, at the position 4, only retain the axial degree of freedom (constraint UX , UY directional of freedoms), which can simulate the entire axle support in two support status above the wheel, shown as Fig. 6.

2.3 Five key positions in the meshing process of gears

Based on transverse contact ratio, a pair of tooth begins to mesh at point A and exit the meshing at E point in the meshing process. In the BD section, there are N pairs of teeth meshing at the same time, namely the meshing zone of N teeth; there are $N+1$ pairs of teeth meshing at the same time in the AB and DE section (N is the integer part of contact ratio value ϵ_γ), shown as Fig. 7. K is any point on the line segment AE and means any meshing position of a gear pair in any instant, shown as Fig. 8.

In the process of finite element analysis, it is necessary to pay close attention to the five key positions. The angle relationship between them can be calculated as follows:

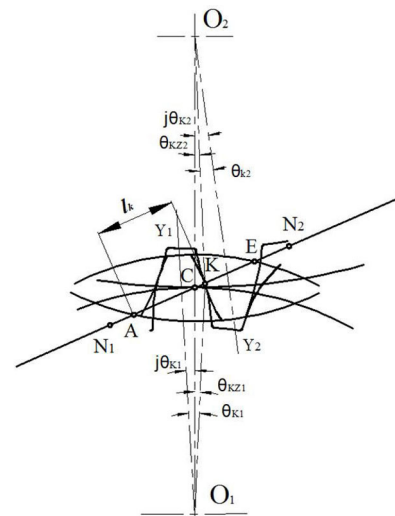

Fig. 7 Five key positions

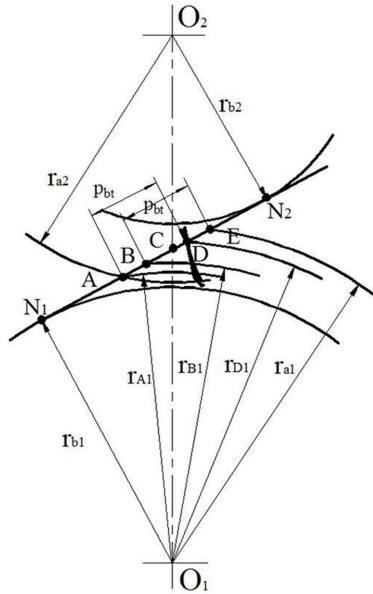

Fig. 8 Diagram of rotation angle relationship

$$S_i = m_i \left(\frac{\pi}{2} + 2 \tan(\alpha_n) \cdot x_{ni} \right); \quad (3)$$

$$\theta_{Ki} = \left(\frac{S_i}{r_i} - 2r_{Ki} (\text{inv}(\alpha_{Ki}) - \text{inv}(\alpha_i)) \right) / 2; \quad (4)$$

$$\theta_{KZ1} = \arccos \left(\frac{a_s^2 + r_{K1}^2 - r_{K2}^2}{2 \cdot a_s \cdot r_{k1}} \right); \theta_{KZ2} = \arccos \left(\frac{a_s^2 + r_{K2}^2 - r_{K1}^2}{2 \cdot a_s \cdot r_{k2}} \right); \quad (5)$$

$$j\theta_{Ki} = \theta_{Ki} - \theta_{KZi}. \quad (6)$$

Where: $i = 1, 2$, represents the big and small gear respectively; $K = A, B, C, D, E$, represents the five special positions; S_i is the tooth thickness of dividing circle; α_{ki} is pressure angle of the five special positions; α_s is the centre distance; r_i and α_i are the radius and pressure angle of any point; θ_{ki} is a half of the central angle corresponding to the tooth thickness of special points; θ_{kzi} is the angle between the radius and the line of center at the special contact points; $j\theta_{ki}$ is the corner relative to the previous position. It is important to note that the sign of $j\theta_{ki}$ of point A and B, C and D changes during the meshing process, and the mark is opposite between the pinion and the large gear according to the meshing principle.

3 Analysis about the finite element calculation results

In the work process, traction gear need to adapt to the requirements of various different working conditions, and due to the change of locomotive driving direction, traction gears have two kinds of working conditions: Front Guide Surface of Motor and Back Guide Surface of Motor. Under different working conditions, the influence of the support structure is different, so load and stress distribution on tooth surface are also different. Because of the length, this paper just analyzes the starting condition of Front Guide Surface in locomotive running process.

Table 1 The starting condition

Operating Conditions	Vehicle Speed (km/h)	Power (kw)	Motor Speed (rpm)
Starting Operation	5	136.5	126

3.1 Finite element contact analysis of gear pair

This gear engagement can be divided into two alternately processes, namely single tooth meshing and double tooth meshing. The tooth root bending stress will reach the maximum value when the two gears mesh in the upper bound point D in single tooth meshing zone, it can be expressed by the first principal stress. The maximum value of contact stress will appear at the lower bound point B in single tooth meshing zone and be expressed by the contact pressure between the contact surfaces.

Tooth root bending stress simulation results can be seen from Fig. 9-10 and surface contact stress simulation as Fig. 11. The maximum of tooth root bending stress of the pinion at the worst point is 480 MPa (theoretical maximum bending stress is 491 MPa, the error is 2.2 %), the location is away from the motor and below the upper bound point of single tooth meshing zone; the maximum of tooth root bending stress of the big gear is 508 MPa (theoretical maximum bending stress is 505 MPa, the error is 0.6 %), the location is close to the motor and below

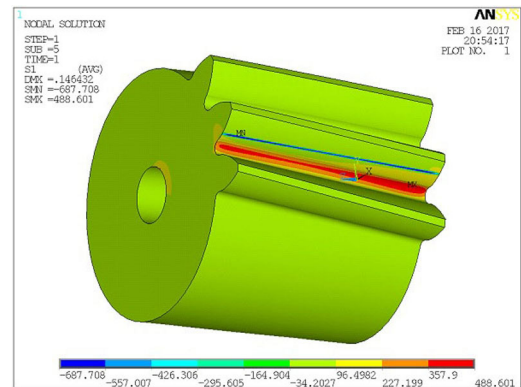

Fig. 9 The bending stress of the pinion

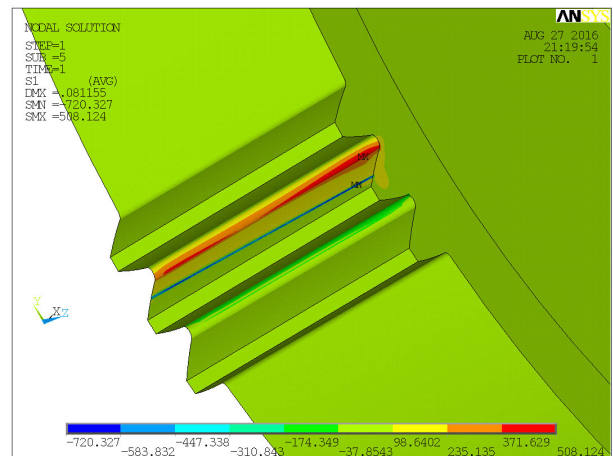

Fig. 10 The bending stress of the big gear

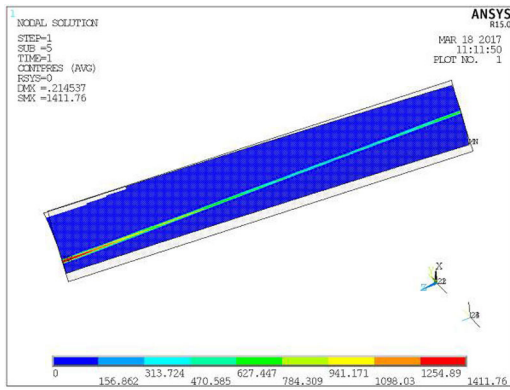

Fig. 11 The contact stress of the gear pair

the upper bound point of single tooth meshing zone; the contact stress is 1411 MPa (theoretical calculation of the maximum contact stress is 1391 MPa, the error is 1.44 %), the location is the lower bound point of the single tooth meshing zone. The stress value and distribution are consistent with the theoretical analysis. So the standard involute gear model is accurate, and it can be the foundation for next analysis.

3.2 Finite element contact analysis of gears with shafts

The results considering shaft parts are shown as Fig. 12-15. The stress of tooth surface near motor side changes significantly, the leaning load in contact of gears is appeared obviously. As a result of the gear leaning, the tooth contact stress exceeds the permissible stress of gears. The tooth root bending stress of the pinion has reached 512 MPa (permissible bending stress is 500 MPa), and contact stress near the motor side also increase seriously, as Fig. 13. Due to the leaning loads, a very obvious edge effect of the tooth appears near the edge, the highest value reached 2139 MPa (permissible contact stress is 1500 MPa). Stress concentration is very serious (Wei and Tang, 2013).

Through the comparison of the results of the separate gear pair and the gear pair with shaft parts, in the course of transmission, the influence of the installed position of the gear pair

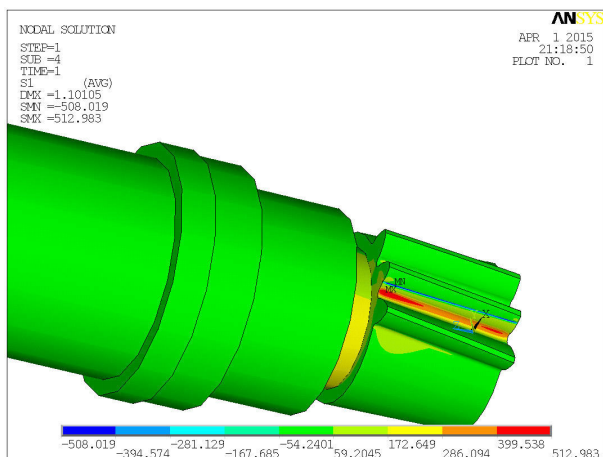

Fig. 12 The bending stress of the pinion

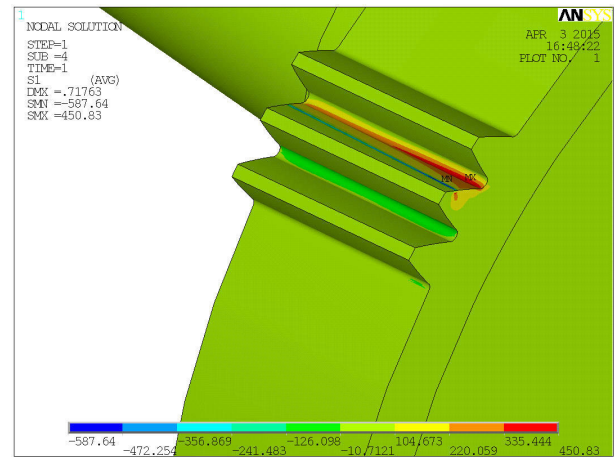

Fig. 13 The bending stress of the big gear

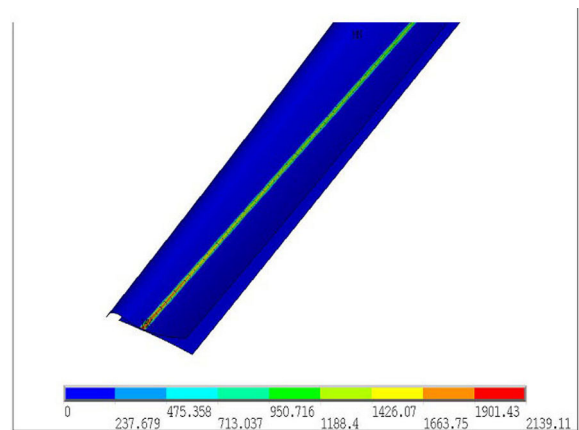

Fig. 14 The contact stress of the traction gear pair

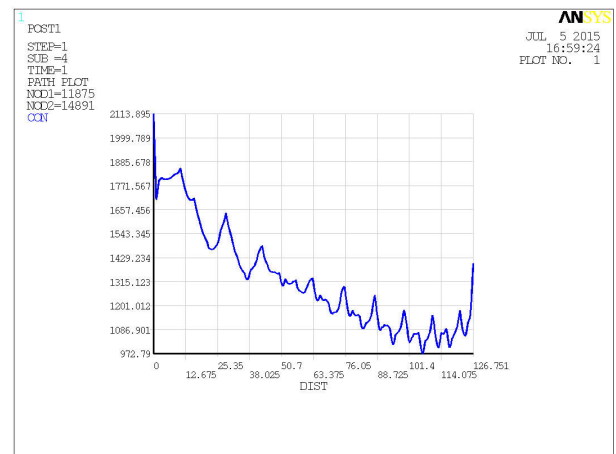

Fig. 15 The contact stress curve of the gear pair

between the bearings, and the elastic deformations of the support shafts can't be ignored.

4 Longitudinal modification

4.1 The purpose

Under the loads, elastic deformations, bending deformations, shear deformations and contact deformation of the transmission shafts and gears will be affected so that the gear leaning phenomenon will appear.

In order to improve tooth contact state and increase the service life of the gears, the longitudinal modification must be carried out. The method of longitudinal modification is to modify the axial profile of the gear according to the deformation rule of the gears generated by the load. In the locomotive traction gears, the big gear has more teeth, larger diameter and smaller deformation, therefore the pinion is chosen to be modified.

4.2 Structural deformation analysis

Firstly, the axial load distribution of the locomotive traction gears in the engaging process should be studied. During the transmission, the contact status of traction gears is affected by all the following factors: deformations of gear itself and spokes; the small gear on the motor shaft as a cantilever beam will produce large deflection when driving; under the loads of upper parts, the traction force and additional dynamic load which is changed with the working conditions, the big gear fixed on the axle of locomotive will be bended and tilted; in addition, the bearing clearance in the axle box type transmission structure will cause bending and contact deformation of the gears; the original gap between the tooth caused by the manufacturing error are non-uniform. All above factors will cause the mesh deformations of gear pair, the teeth will contact along one side more obviously and seriously, the load distribution will be more uneven.

Take the Front Guide Surface as an example to analyze the deformation law of the motor shaft and axle. In the process of moving forward, the pinion rotates clockwise, and the right side of the tooth (Front Guide Surface) involves in meshing, as shown in Fig. 16. According to the direction of its movement, at the meshing point, the direction of the circumferential force of the pinion is upward and the circumferential force of the big gear is downward. Under the action of the force, the deformation direction of the motor shaft is upward on both ends and downward on the middle part, and that of the axle is downward on both ends and upward on the middle part. The relative angle of gear pair is the sum of the inclination of pinion and large gear (Bao et al., 2009).

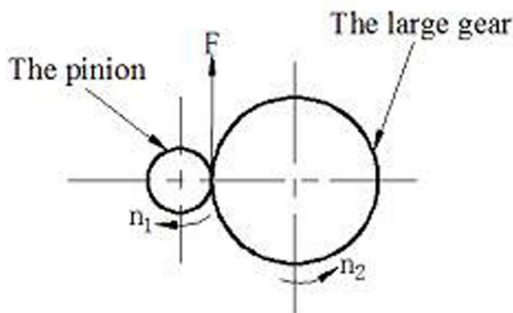

Fig. 16 The deformation diagram of the motor shaft and axle

4.3 The parameter of tooth longitudinal modification

The gear inclination created by multiple causes is very difficult to calculate before, but it is easy to complete this process by the finite element method. Based on the principle of tooth longitudinal modification, the elastic deformation curve of the gear need to be extracted, and it will be the basis of the longitudinal modification.

The process of the locomotive driving forward (the upward side of Fig. 1), the deformations of the motor shaft and the axle are in the opposite directions, so the total deformation is the sum of two axes deformations. The curves are shown as Fig. 17. Integrated deformation curve is the top one, namely antisymmetric curve of tooth longitudinal modification (Zheng, 2015).

From the Fig. 17, the maximum value of the total deformation is 0.1498 mm, and the minimum value is 0.0377 mm. The modification curve of the unilateral tooth surface can be obtained by the inverse deformation principle. But in actual working condition, taking into account other errors and convenient processing, in accordance with the simulation parameters, the modification curve will be designed as the approximate drum.

According to the minimum and maximum deformation values, the radius of crowned tooth is designed as R_K , the maximum amount of crowned tooth is 0.1498 mm. Because the pinion is

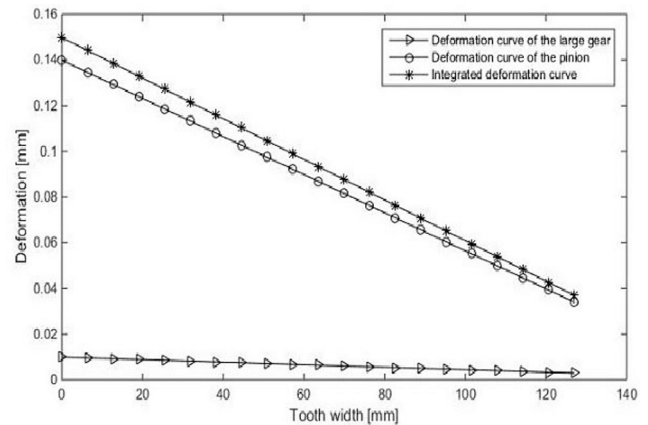
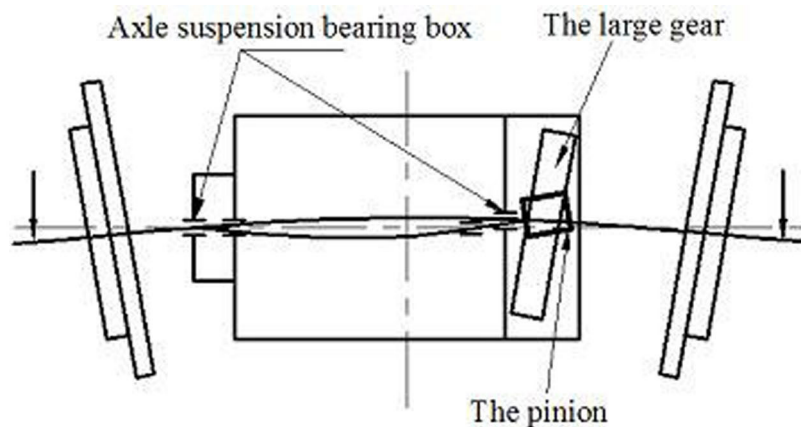

Fig. 17 The sketch of deformation of the gears



a cantilever arrangement, the center position of crowned tooth should deviate away from the end of the motor for better modification effect, and the eccentricity ΔW is gotten by calculation.

In order to calculate conveniently, the involute helical surface is often expanded into a space plane along the base cylinder, as Fig. 18, after the expansion, the helix is turned into an oblique line.

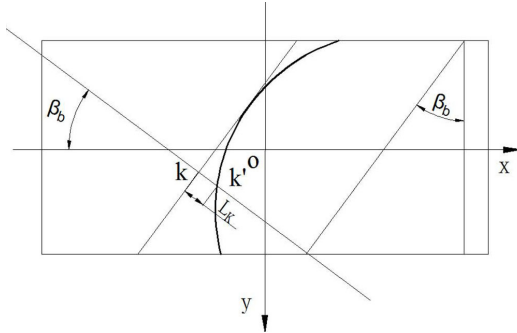

Fig. 18 The expansion plan of helical gear

Coordinate system $S(x, y, z)$ is located on the pinion, point O_1 is located on the neutral position of the tooth width, shown as Fig. 19. After the modification, radius R_K , the maximum amount of drum ΔL and drum center eccentricity ΔW are all determined, the amount of modification L_K is only a function of y_K (y coordinate values of point K).

$$\begin{cases} R_K^2 = (R_K - L_K)^2 + (y_K + \Delta w)^2 \\ R_K^2 = (R_K - \Delta L)^2 + (B/2 + \Delta w)^2 \end{cases} \quad (7)$$

K is an arbitrary point to be modified in the longitudinal direction of the tooth. R_K is the modification radius of crowned tooth; ΔL is the maximum amount of modification, B is the tooth width; ΔW is the eccentricity; L_K is the modification amount of any point along the engagement line. After calculation, the parameters are taken as: $R_K = 74000$ mm, $\Delta W = 24.6$ mm, $\Delta L = 0.15$ mm.

The projection drawing of the gear tooth after modification in transverse plane is shown as Fig. 20. $K(x_d, y_d)$ is an arbitrary point on the curve without modification. $K'(x'_d, y'_d)$ is an

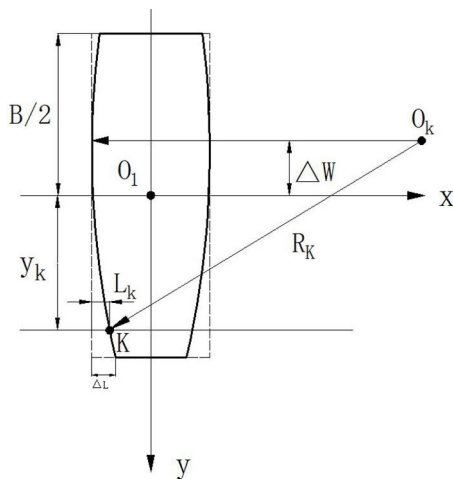

Fig. 19 The projection drawing of the tooth after longitudinal modification

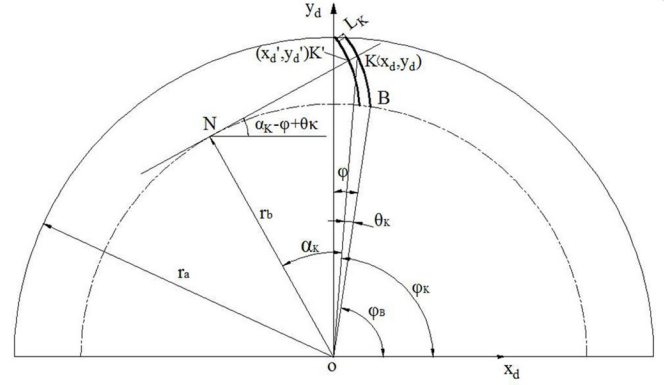

Fig. 20 The transverse plane projection of the tooth of pinion before and after modification

arbitrary point on the curve after modification which is equivalent to the K point moves the distance L_K along the engagement line. The relationship between the two points is:

$$\begin{cases} x'_d = \frac{r_b}{\cos(\alpha_K)} \cos(\phi_B + \theta_K) - L_K \cos(\alpha_K - \phi + \theta_K) \\ y'_d = \frac{r_b}{\cos(\alpha_K)} \sin(\phi_B + \theta_K) - L_K \sin(\alpha_K - \phi + \theta_K) \end{cases} \quad (8)$$

Where: α_K is the independent variable (its range changes from 0 to α_a , α_a is the addendum circle pressure angle); r_b is base circle radius; α_K, θ_K are pressure angle and the generating angle of the involute in point K ; ϕ_B, ϕ_K are polar angles in the point B (the starting point of the main involute) and arbitrary point K on the base circle; ϕ is circumference angle corresponding to the tooth thickness of base circle.

In the whole process of the modification, the parameters in the Z direction are not changed, so there is no discussion.

4.4 The establishment of the modified model

In much literature, the trace modification was completed with traditional 3D modeling software, such as Pro/E, SolidWorks, Romax (Oh et al., 2013) and so on, but the veracity of the model and the accuracy of the modification quantity may be reduced when importing the models into ANSYS. In order to solve this problem, the modified gears would be reconstructed directly in ANSYS.

In ANSYS, the finite element model is composed of a large number of units, and each unit contains a certain number of nodes. The information of all nodes and units is stored in the database of ANSYS. On the basis of that, the method of modifying the coordinates of nodes on tooth surface can help to achieve the purpose of tooth longitudinal modification.

Based on the standard helical gear pair model established before, first of all, select the teeth to be modified and extract the nodes on the modification surface as Fig. 21, establish a node-set Area-Node. In the local cylindrical coordinate system, use the command *Get to extract the numbers and

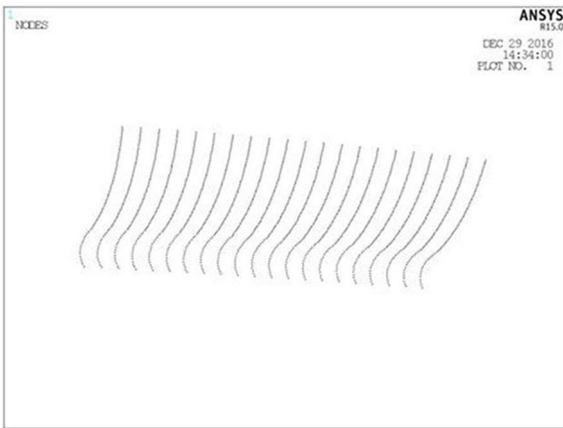

Fig. 21 Nodes on the modified tooth surface

Array Parameter ARRAY1				
File Edit Help				
Page Increment	Full Page	View Plane	z = 1	
Initial Constant	0			
Selected: NONE				
	1	2	3	4
531	8492	82.3942779	92.4850545	69.8499891
532	8493	82.3942779	93.0695026	76.1999891
533	8494	82.3942779	93.6539507	82.5499891
534	8495	82.3942779	94.2383988	88.8999891
535	8496	82.3942778	94.8228468	95.2499891
536	8497	82.3942777	95.4072948	101.5999891
537	8498	82.3942779	95.9917431	107.9499891
538	8499	82.3942781	96.5761913	114.2999891
539	8500	82.3942784	97.1606375	120.6499891

Fig. 22 Extracting number and coordinates of nodes

coordinates of all nodes in the set of nodes, store them in array Array1, as Fig. 22.

Write the program in APDL to extract all the information on the teeth to be modified, including the type of the unit, the number of nodes, and the serial number of nodes contained in each unit; store them in the arrays Array2 and Array3 respectively; then, delete the elements and solid models of the gear teeth to be modified, as Fig. 23.

According to the coordinates stored in array Array1, the new coordinates of all the nodes are calculated by Eq. (8), the data obtained are still stored in array Array1. Use the coordinates and number information stored in the array Array1, Array2, and the unit information in the array Array3 to regenerate the nodes and units through the procedure, as Fig. 24. At last, reading nodes of the entire gear and nodes of modified tooth surface with the N command in turn, and reconstructing elements by reading the element information. After these work, the longitudinal modification of the gear is achieved.

The profile curve after modification is generated, and the contrast is as Fig. 25, 26. Near the end of the motor, the obvious gap between the two teeth after modification is appeared. In the contact analysis, the contact surface offset is adjusted in order to guarantee the initial contact.

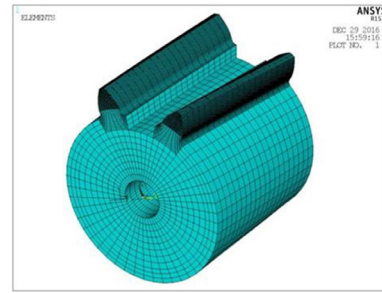

Fig. 23 Remove the modified gear

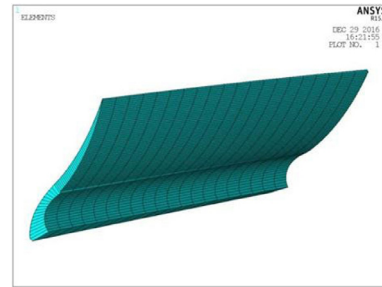

Fig. 24 Reconstruction of the modified tooth surface

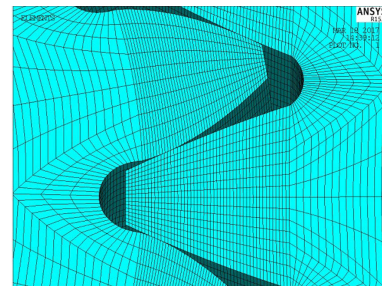

Fig. 25 The meshing condition of the gear pair before modification

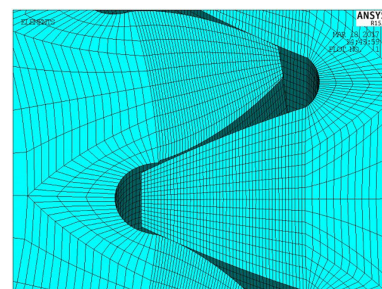

Fig. 26 The meshing condition of the gear pair after modification

5 Result analysis after modification

Apply load on the gear and shaft parts after modification, and extract the bending stress and contact stress of the gear pair, shown as Fig. 27, 28, 29. It can be seen the effect of tooth longitudinal modification is very obvious. The stress values of the two sides of gears are decreased, and the unbalance loading is improved obviously. The maximum bending stress and contact stress are all in the middle part of the gear tooth. The first principle stress in the middle position of the pinion is 454 MPa and that of the big gear is 420 MPa; the maximum contact stress that appears at the middle position of the gear tooth is

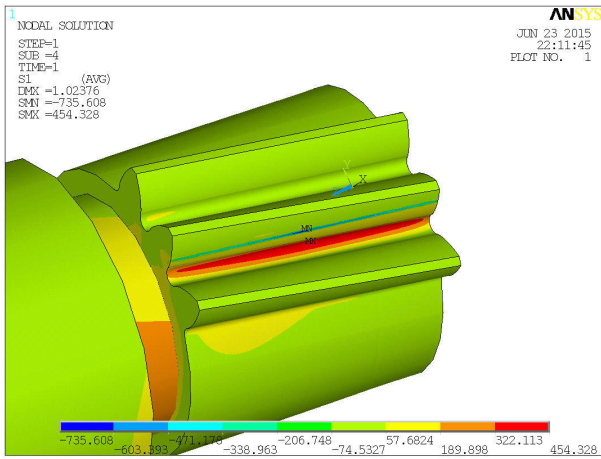

Fig. 27 The bending stress of the pinion after modification

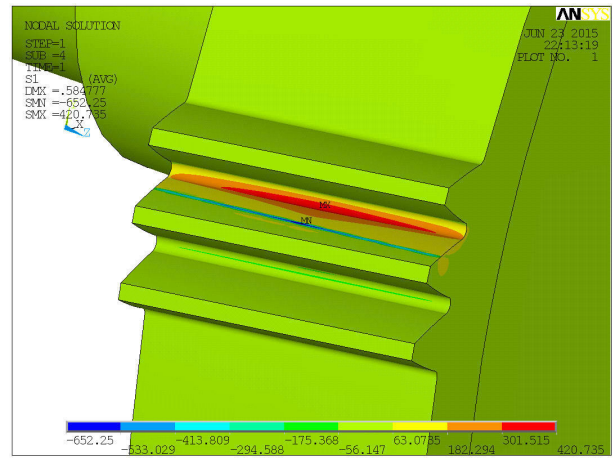

Fig. 28 The bending stress of the big gear after modification

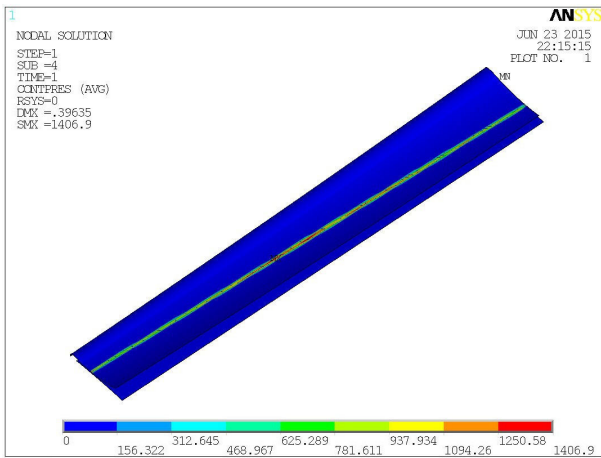

Fig. 29 The contact stress of the traction gear pair after modification

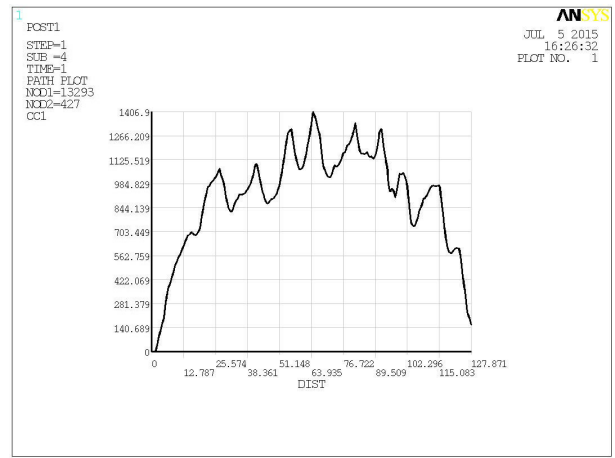

Fig. 30 The contact stress curve of the traction gear pair after modification

1406.9 MPa; the contact stress distribution of the gear pair is extracted along the engagement line as Fig. 30. The maximum contact stress occurs at the midpoint of the tooth width, and the variation law is the biggest value appears in the middle of the tooth width and gradually reduces on both sides, the value is close to zero in both ends of the engagement line. Obviously, the stress concentration phenomenon has been improved obviously, the edge contact disappears (Wu et al., 2011).

According to the changes of the bending stress and the contact stress, the conclusion can be drawn: the radius of crowned tooth, the amount of tooth longitudinal modification and the center position of the crowned tooth are all reasonable. The tooth longitudinal modification ensures the contact along the middle part of tooth and meshing status is improved significantly.

6 Conclusions

According to the actual structure and driving characteristics of high-speed and heavy-load traction gears, the working process of them is studied. The specific conclusions are as follows:

- (1) Combined with the actual structure, installation method and load characteristics of the locomotive traction gears, according to the design radius of top circular arc of single

round grinding hob and the gear parameters, accurate contact simulation of the traction gears has been finished.

- (2) Based on the analysis of bending fatigue strength and contact fatigue strength of the traction gears with shafts, the amount and curve of tooth longitudinal modification are determined. In order to ensure the accuracy of the analysis, the modified model was also built and analyzed in ANSYS.
- (3) The tooth longitudinal modification reduces the load on both ends of the teeth, improves the stress concentration and eliminates the phenomenon of partial load. It also shows the modification methods and the amount of the modification are reasonable.

Acknowledgement

The project presented in this article is supported by Collaborative Innovation Center of Major Equipment Manufacturing in Liaoning.

References

- Bao, J., He, W., Li, L. (2009). Parametric solid modeling and dynamics analysis of high-speed locomotive traction gear. *Journal of Mechanical*. 33(5), pp. 70-75. (in Chinese)
<https://doi.org/10.16578/j.issn.1004.2539.2009.05.019>
- He, W., Wang, Y., Bao, J. (2011). Finite Element Analysis of Electric Locomotive Transmission System Supporting Structure. *Journal of Dalian Jiaotong University*. 5(32), pp. 42-46. (in Chinese)
<https://doi.org/10.13291/j.cnki.djdxac.2011.05.020>
- Oh, S., Oh, S., Kang, J., Lee, I., Lyu, S. (2013). A Study on Modeling and Optimization of Tooth Micro-geometry for a Helical Gear Pair. *International Journal of Precision Engineering and Manufacturing*. 14(3), pp. 423-427.
<https://doi.org/10.1007/s12541-013-0058-2>
- Shang, Z., Wang, H. (2009). Finite Element Analysis of Modified Wide Helical Gears. *Transactions of the Chinese Society for Agricultural Machinery*. 40(2), pp. 214-219. (in Chinese)
- Sun, H., Chen, Z. (2003). *Mechanical Theory*. Sixth Edition, Higher Education Press, Beijing, China.
- Wei, Y. G., Tang, W. C. (2013). The Edge Effect and Longitudinal Modification of Involute Gear Drive Used in Automobile. *Applied Mechanics and Materials*. 367, pp. 136-140.
<https://doi.org/10.4028/www.scientific.net/AMM.367.136>
- Wu, Y., Wang, J., Han, Q., Li, Q. (2011). Tooth Profile Modification of Helical Gears and Experimental Study based on Finite Element Contact Analysis. *Journal of Aerospace Power*. 26(2), pp. 409-415. (in Chinese)
<https://doi.org/10.13224/j.cnki.jasp.2011.02.006>
- Wu, Y., Wang, J., Han, Q. (2012). Static/dynamic contact FEA and experimental study for tooth profile modification of helical gears. *Journal of Mechanical Science and Technology*. 26(5), pp. 1409-1417.
<https://doi.org/10.1007/s12206-011-1028-1>
- Zheng, J. (2015). Analysis of Locomotive Traction Gear Profile Modification based on APDL. *Journal of Dalian Jiaotong University*. 36(6), pp. 15-19.