

THE INFLUENCE OF MICROELECTRONICS TO PRECISION MECHANICS DESIGN

O. PETRIK

Institute of Precision Mechanics and Optics
Technical University, H-1521 Budapest

Received March 10, 1988

Abstract

The microelectronics gives numerous new possibilities to design such a new type of devices in which the electronics and precision mechanics are integrated to fulfill new requirements. The extremely small dimensions of microelectronics is advantageous for this integrations of the control, of the information acquisition, transfer and evaluation, of decision making activities, together with the actuation, positioning and manipulating activities of precision mechanics; can achieve a new high performance of devices. Some concepts and examples for mechatronical design are given in this paper.

Introduction

During few decades electronics has undergone an enormous development. There are numerous results and functions in creative design, to be achieved better by electronic means than without it. The newest LSI and VLSI circuits have such little dimensions, that they can directly be integrated into the mechanical, pneumatical etc. components. In this way the electronics, in general, can take over some functions from other types of system parts. Electronics shares the different functions with the mechanical subsystems. On this basis the industry produced a new type of devices, in which the tight integration of electronics and mechanics exists (called "mechatronics"). The tendency mentioned above causes a change in the design concept of mechanical parts integrated to electronics.

Characteristics of mechatronics

The mechatronical subsystem has both the functions of two component systems i.e. the electronics and (precision) mechanics:

Performance of *electronics*:

- Information taking and coding
- Storing of information

- Information evaluating
- Decision making and command preparing and transmitting.

Mechanical performance

- Performing: displacement, force, rotation etc.
- Positioning of parts and workpieces,
- Operations (machining, grinding etc.) fulfilling,

Driving, actuating, manipulating ect. The performance of a mechatronical unit consists of the complex function of the above mentioned ones. This complexity requires a new approach in the design. The addition of the information handling possibility enlarges the efficiency of the mechatronical parts to better performance. The complex mechatronical unit is able to control and guide the subsystem, to make correction (i.e. compensate the nonlinearity), to search for the optimal performance circumstances etc. After all, in the design process you have to take into consideration the new flexibility and the "intelligency" of the complex system giving electronics a kind of additional gain.

Some mechatronical units (Examples)

The control of a driving unit can be solved by a simple variable speed gear box connected to an electrical servomotor (Fig. 1). This is an inadequate solution because of the small controllability. The servomotor at especially low RPM gives very small power.

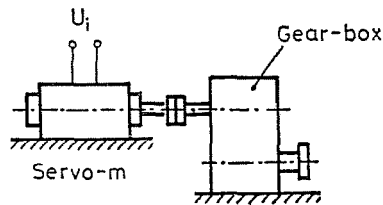

Fig. 1

The electronic control solved the problem by a simple circuit, using an operational amplifier (Fig. 2).

The results were as follows:

- Continuous and high controllability,
- Yields power also at low RPM,
- Small dimension (match-box measures),
- Comparatively cheap manufacturing
- Excellent reliability (better than in the case of mechanics).

The system can be built up by simple (outside excited) servomotors as shown in Fig. 2.b.

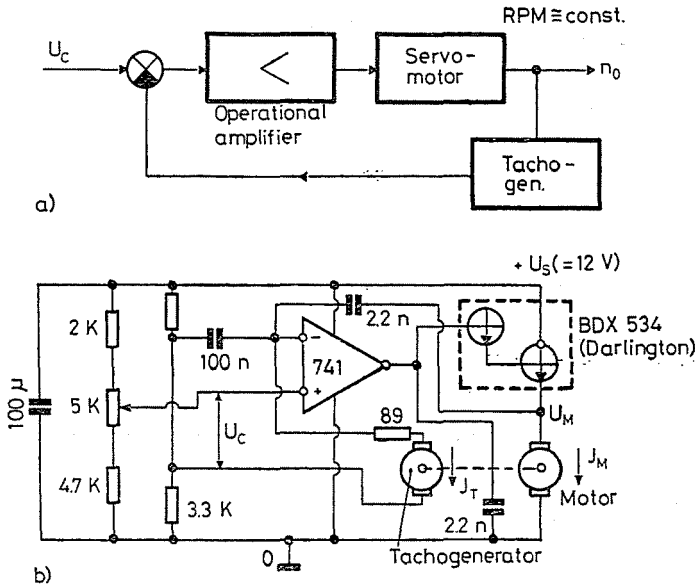

Fig. 2

Another problem is to assure a *constant RPM*. The totally mechanical design is made possible by a brake controller (Fig. 3.). This is a very simple and reliable mechanism, but the accuracy is not enough for HIFI devices e.g. The mechatronical variant is shown by Fig. 3.b. This is a complex optomecha-electronical system. The characteristics of this are as follows

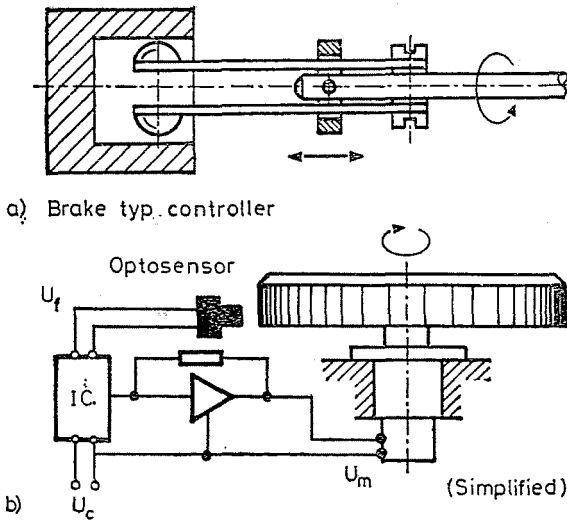

Fig. 3

- Very high accuracy (in RPM constancy)
- Good controllability
- Constant characteristics (time invariant)
- High reliability etc.

Compensation of nonlinearity by electronics

The nonlinear characteristics of components or subsystems always caused great problems. The compensation was difficult both mechanically and by electronics. The μ P-s and the use of microcomputers give a new approach to this compensation. If (and only if) the nonlinearity were steady, the compensation is possible.

In Fig. 4 the concept of compensation is shown. The characteristics of this system are the following:

- The accuracy of linearisation can be prescribed
- The hardware is relatively inexpensive
- The connection to computer is directly possible
- A previous, carefully made calibration is necessary.

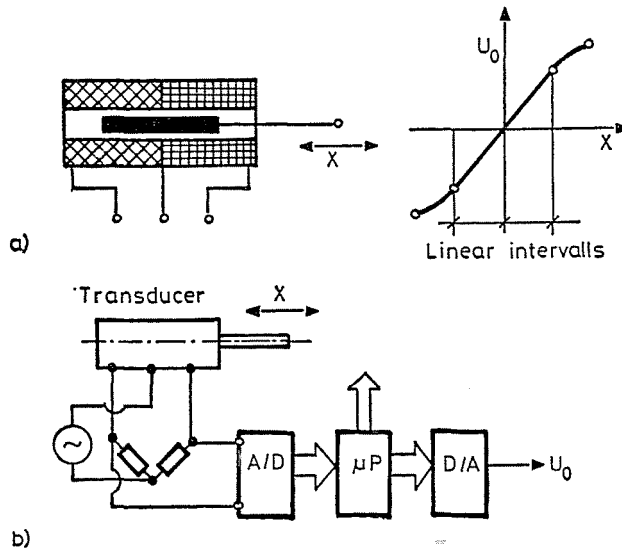

Fig. 4

The indirect influence of microelectronics of precision mechanics design

The up to date manufacturing, the NC and CNC techniques assure the production of "sculpturlike" surfaces, without extremely high costs. It means, we have not to be constrained to design "basic shapes" (ie, sperical, cylindrical, conoidal, plane etc.). We have the possibility to realize *complex functional surfaces* without any connections or fittings (screws, revits etc.). This means that the design of three-dimensional devices becomes easy, and it results in inexpensive products.

Another enormous help of the electronics towards the mechanical design is *computer graphics*. You can consider and check numerous solutions by graphical simulation. The different CAD systems are nowadays in development, and will change the design methodology of all the different fields of modern technology.

References

- LINDER, W.: Finommechanika. (Precision Mechanics) Műszaki Könyvkiadó Bp. 1977.
MASSZI, F., SZAMOSKÖZI, Z.: LSI-VLSI áramkörök, felépítése, tesztelése, alkalmazása (LSI-VLSI circuits. Structure, testing, application), (In Hungarian). Műszaki Könyvkiadó, Bp. 1985.
PETRIK, O.: A "mechatronika" mint a finommechanika, és az elektronika újszerű kapcsolata ("Mechatronics" as a novel connection between precision mechanics, optics and electronics). Finommechanika-Mikrotechnika 25. évf. 1986. dec. p 354—356 (In Hungarian).

Prof. Dr. Oliver PETRIK, H-1521, Budapest.